



EAN code  
CRM-102: 8595188197120

**Technical parameters CRM-102**

**Power supply**

Supply terminals:	L-N
Supply voltage:	AC 100 – 240 V, DC 145-335 V (50-60 Hz)
Consumption (max.):	??? VA/??? W
Supply voltage tolerance:	-15 %; +10 %

**Time circuit**

Time delay (t0):	90 s
Time delay (t1a + t1b):	1 – 60 m (t1=t1a + t1b)
Time delay (t2):	0.5 – 120 s*
Time setting:	rotary switches and potentiometers
Time deviation:	5 % – mechanical setting
Repeat accuracy:	0.2 % – set value stability
Temperature coefficient:	0.01 %/°C, at = 20 °C (0.01 %/°F, at = 68 °F)

**Output**

Contact type:	6x closing (AgSnO <sub>2</sub> )
Current rating:	10 A/AC1
Breaking capacity:	2 500 VA/AC1
Switching voltage:	AC 250 V
Power dissipation (max.):	3.6 W
Mechanical life:	10.000.000 op.
Electrical life (AC1):	100.000 op.

**Control**

Control buttons:	IN1 - IN6, MOFF
Buttons power supply:	Internal / DC 12 V
Control inputs:	MC, CS (potential-free contacts) MD (galvanically isolated)
Input (MD) power supply:	AC/DC 12 – 240 V
Impulse length:	min. 25 ms / max. unlimited
Reset time:	max. 150 ms

**Other information**

Operating temperature:	-20 .. +55 °C
Storage temperature:	-30 .. +70 °C
Dielectric strength:	AC 4kV (supply – output)
Operating position:	any
Mounting:	DIN rail EN 60715
Protection degree:	IP40 front panel / IP20 terminals
Oversvoltage category:	III.
Pollution degree:	2
Cross-wire section; solid/ stranded with ferrule (max.):	1x 2.5 mm <sup>2</sup> (14 AWG), 2x 1.5 mm <sup>2</sup> (16 AWG)/ 1x 2.5 mm <sup>2</sup> (14 AWG), 2x 1.0 mm <sup>2</sup> (17 AWG)
Dimensions:	90 x 35 x 64 mm
Weight:	??? g
Standards:	EN 61812-1

\* Time t2 can be limited by time t1  
(t1 = 1 m, t2 = max. 30 s)  
(t1 = 2 m, t2 = max. 1 m)

- Time relay for automatic lighting control in hotel rooms
- Control inputs:  
6x switch button with ON/OFF function (one for each output contact)  
1x MASTER OFF switch (controls all output contacts)  
CS - card switch (potential-free contact)  
MC - magnetic door switch (potential-free contact)  
MD - motion detector > infrared sensor (universal galvanically isolated input)
- Possibility to select the type of control inputs (normally open or normally closed)
- All buttons switch a safe DC 12 V voltage from an internal source
- Time delay t1 (delayed lighting switch-off)  
- adjustable in the range of 1 - 60 m in minute steps
- Time delay t2 (blocking input for motion detector)  
- continuously adjustable in the range of 0.5 – 120 s
- Supply voltage AC 100 – 240 V, DC 145 – 335 V
- Output contact: 6x normally open 10 A/250 V with zero-cross switching
- Green LED indicates the presence of supply voltage
- Multifunction red LED flashes or lights up depending on operating state
- Yellow LED indicates the closed state of any output



The output contacts use ZERO-CROSS technology, which switches the load at the moment the voltage crosses zero. This ensures gentle switching without sudden transients, which significantly extends the life of the contacts - especially when switching electronic ballasts and LED luminaires.

**Description**

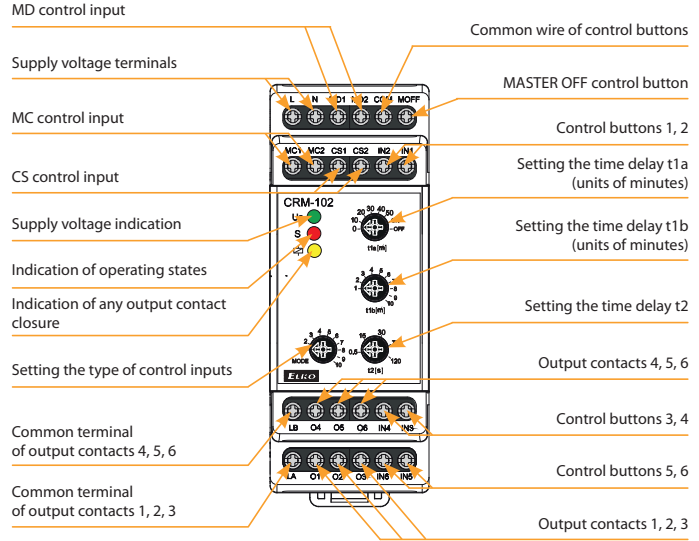

**Connection**

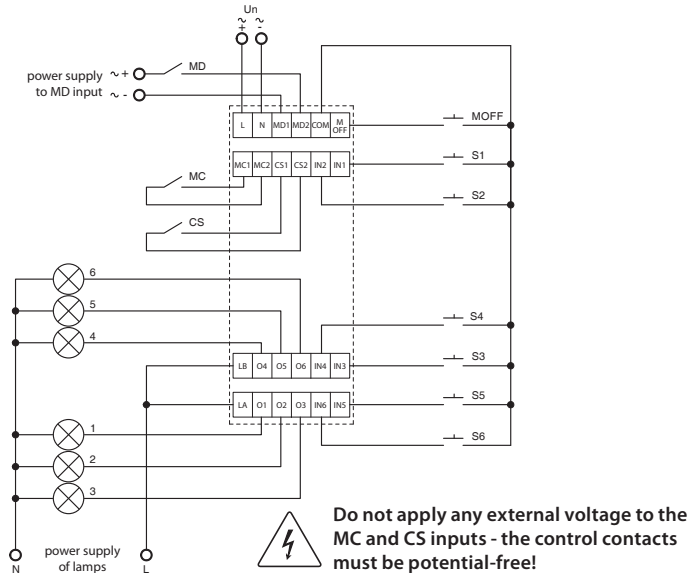

**Do not apply any external voltage to the MC and CS inputs - the control contacts must be potential-free!**

Setting the type of control inputs

MODE	MD	MC	CS
1	NO	NO	-
2	NO	NC	-
3	NC	NO	-
4	NC	NC	-
5	NO	NO	-
6	NO	NC	-
7	NC	NO	-
8	NC	NC	-
9	-	-	NO
10	-	-	NC

Setting example:

Operation controlled by MC and MD inputs:

- MC (door contact) is NC (closed when door is closed)
- MD (motion detector) is equipped with an NC contact (closed at rest, open when motion is detected)
- CS (card switch) is not used
- MODE must be set to position 4 or 8

Operation controlled by CS input:

- MC (door contact) is not used
- MD (motion detector) is not used
- CS (card switch) is NO (open without inserted card, closed with inserted card)
- MODE must be set to position 9

Test mode – card switch does not need to be connected:

- MC (door contact) is not used
- MD (motion detector) is not used
- CS (card switch) is NC (closed without inserted card, opened with inserted card)
- MODE must be set to position 10

Functions 1, 2, 3, 4 (5, 6, 7, 8)

The graph and description of the function correspond to the setting of the MODE 1 control inputs.

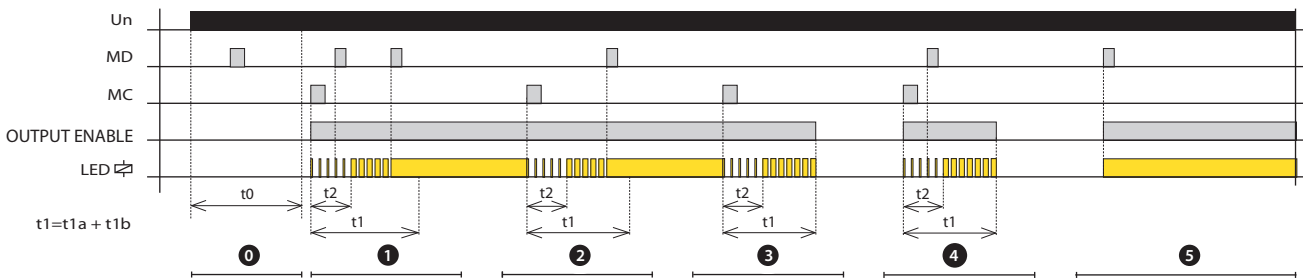

Function notes:

- When the OUTPUT ENABLE state is active, all output contacts can be controlled using the push-buttons.
- When the OUTPUT ENABLE state is inactive, all illuminated luminaires are switched off and the push-buttons cannot control any output contacts.
- Functions 5, 6, 7, and 8 replicate (mirror) functions 1, 2, 3, and 4.

0 Blocking of the motion detector

After power-up, the MD input (motion detector) is blocked for the duration of time delay t0.

1 Entering the room

When persons enter the room, the MC input (magnetic door contact) is activated:

- The OUTPUT ENABLE state is activated and the time delays t1 and t2 are started simultaneously.
  - The red LED flashes according to the active time delay.
- The MD contact responds to movement of persons in the room:
- During time delay t2, the MD input is blocked.
  - If the MD input is activated after time delay t2 has elapsed, time delay t1 is cancelled and the red LED lights steadily. The OUTPUT ENABLE state remains permanently active.

2 Leaving the room

When a person leaves the room, the MC contact is activated:

- The time delays t1 and t2 are started simultaneously.
- If motion is detected in the room after the time delay t2 has elapsed, the MD input is activated, the delay t1 is cancelled, and the OUTPUT ENABLE state remains permanently active.

3 Leaving the room – last person

When the MC contact is activated as the last person leaves the room:

- The time delays t1 and t2 are started simultaneously.
- If the MD input is not activated after time delay t2 has elapsed (no motion in the room), then after time delay t1 the red LED turns off and the OUTPUT ENABLE state is deactivated (all illuminated luminaires are switched off).

4 No motion after time delay t2

When a person enters the room, the MC input is activated:

- The OUTPUT ENABLE state is activated and the time delays t1 and t2 are started simultaneously.
- If the MD input is not activated after time delay t2 has elapsed (e.g. a brief entry into the room), then after time delay t1 the red LED turns off and the OUTPUT ENABLE state is deactivated (all illuminated luminaires are switched off).

5 Motion in idle state

If, after a person leaves the room, the MD input is not activated after time delay t2 has elapsed, the OUTPUT ENABLE state is deactivated (all illuminated luminaires are switched off). However, another person remains in the room without movement (e.g. sleeping):

- If the MD input is subsequently activated (e.g. when the sleeping person wakes up), the OUTPUT ENABLE state is activated immediately, without any time delay.

Functions 9, 10

Function notes:

- These functions use only the CS input (card switch); the MD and MC inputs are not used.
- When the card is inserted, the OUTPUT ENABLE state is activated, allowing all output contacts to be controlled using the push-buttons.
- When the card is removed, the time delay t1 is started; after the delay expires, the OUTPUT ENABLE state is deactivated (all illuminated luminaires are switched off).