



EAN code
DIM-7: 8595188192309

Technical parameters	DIM-7
Power supply	
Supply terminals:	L-N
Supply voltage:	AC 230 V (50-60 Hz)
Consumption (max.):	26 VA/1.8 W
Supply voltage tolerance:	-15%; +10%
Output	
Loadability (max.):	1500 VA*
Output current (max.):	10 A
Power dissipation (max.):	15 W
Control mode	
LOCAL (output 1-10 V OUT not active):	Control inputs S, IN
MASTER (output 1-10 V OUT active):	Control inputs S, IN
SLAVE (input S, IN not active):	Control input 1-10 V IN
DALI (input S, IN, 1-10 V not active):	Control input DA+, DA-
Control input S	
Control voltage:	AC 230 V (-15%; +10%)
Glow lamp connection (max.):	YES (20 mA)
Control input IN	
Control voltage:	AC/DC 12 – 240 V (-15%; +10%)
Galvanically separated:	YES**
Input current (max.):	2 mA
Control 1-10 V	
Galvanically separated:	YES**
Input current (max.):	0.1 mA
Output current +10 V (max.):	10 mA***
DALI control	
Power supply:	DC 16 V
Galvanically separated:	YES**
DALI current (resting state):	2.4 mA
Other information	
Operating temperature:	-20 .. +50 °C (-4 .. 131 °F)
Storage temperature:	-30 .. +70 °C (-22 .. 158 °F)
Operating position:	on a horizontally positioned DIN rail
Mounting:	DIN rail EN60715
Protection degree:	IP40 front panel/IP20 terminals
Overvoltage category:	III.
Pollution degree:	2
Dielectric strength:	AC 4 kV/DC 6.1 kV**
Cross-wire section; solid/ stranded with ferrule (max.):	1× 2.5 mm ² (14 AWG), 2× 1.5 mm ² (16 AWG)/ 1× 2.5 mm ² (14 AWG), 2× 1.0 mm ² (17 AWG)
Dimensions:	90 × 105 × 65 mm (3.5" × 4.1" × 2.6")
Weight:	306 g (10.8 oz)
Standards:	EN 63044-1

* maximum loadability of the device can be increased to 2000 VA provided that the operating temperature is limited to max. +35°C. **Warning:** it is not allowed to connect inductive and capacitive loads at the same time.

** dielectric strength of galvanically separated parts from each other

*** ideal range of external potentiometer is 10 kΩ to 100 kΩ (closer to 10 kΩ, the better - not so sensitive to interference)

- Designed for dimming incandescent lamps, halogen lamps, low-voltage halogen lamps with wound or electronic transformer, dimmable energy-saving lamps and dimmable LED lamps.
- Control via control button (with orientation glow lamp) or galvanically separated input (LOCAL/MASTER mode).
- Control via 1-10 V interface (MASTER/SLAVE mode), possibility of control via external potentiometer in SLAVE mode.
- Control via DALI bus (DALI mode).
- Electronic protection against current overload and short circuit.
- Electronic protection against thermal overload.
- Dimming parameters adjustable by potentiometers on the device panel (min./max. brightness, preheating, dimming curve, dimming speed, dim-up/dim-down time for each input S and IN separately).
- Indication of operating states – power supply, fault states (overload), programming mode.
- Loads can be divided between different phases (when controlling several DIM-7 dimmers together).
- Possibility of joint control of several DIM-7 dimmers with a 1-10 V interface or DALI bus.
- RF and BUS elements can be used to control these dimmers via the 1-10 V interface (RFDAC-71B-SL, DAC3-04M, DAC3-04B, ...).

Description

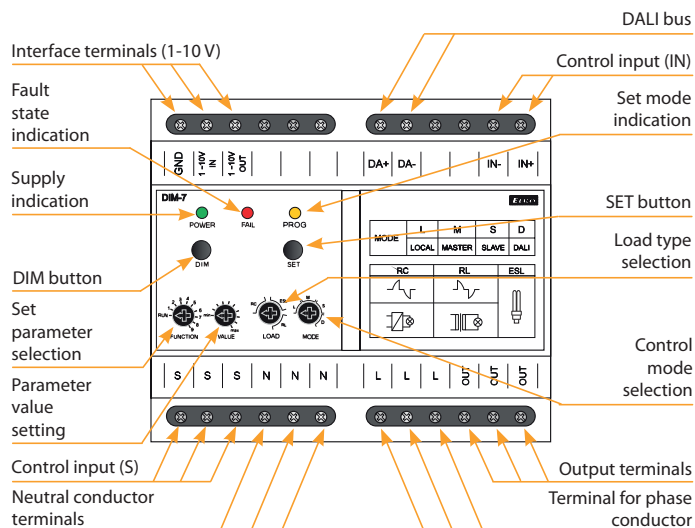

LED indication

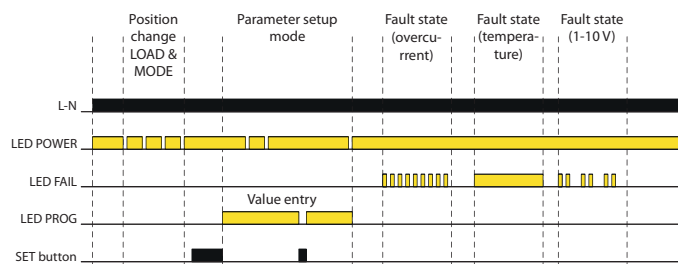

Symbol

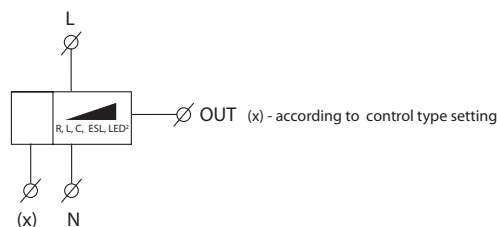

Connection and control modes

LOCAL

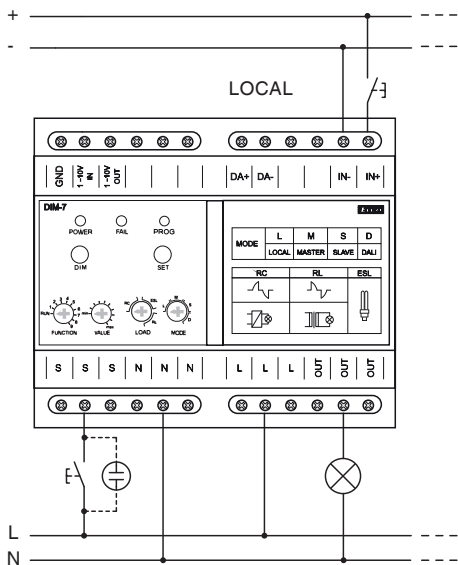

LOCAL

- Button control (with orientation glow lamp) - input S
 - Button control from an external (separate) source - input IN+; IN-
 - DIM button control on the device panel
- In this mode, control by 1-10 V interface or DALI bus is not active.

MASTER

- Button control (with orientation glow lamp) - input S
 - Button control from external (separate) source - input IN+; IN-
 - DIM button control on the device panel
- This mode allows to control other connected dimmers with 1-10 V interface. These other dimmers must be in SLAVE mode. The control dimmer must have 1-10 V IN and 1-10 V OUT terminals connected. In this mode, control by DALI bus is not active.

SLAVE

- Control by interface 1-10 V - either by external control device or external potentiometer (cannot be connected simultaneously)
 - The potentiometer is powered from the 1-10 V OUT terminal, which in this mode has a voltage of +10 V against the GND terminal
- In this mode, control by DALI bus is not active and inputs for control buttons or DIM button on the panel are not active.

DALI

- Control by DALI bus, connected to terminals DA+; DA-
- In this mode, the inputs for control buttons and the DIM button on the panel are not active. Control by 1-10 V interface is also not active. If the DALI bus is interrupted or disconnected, the dimmer is set to an unregulated state (maximum brightness level).

MASTER

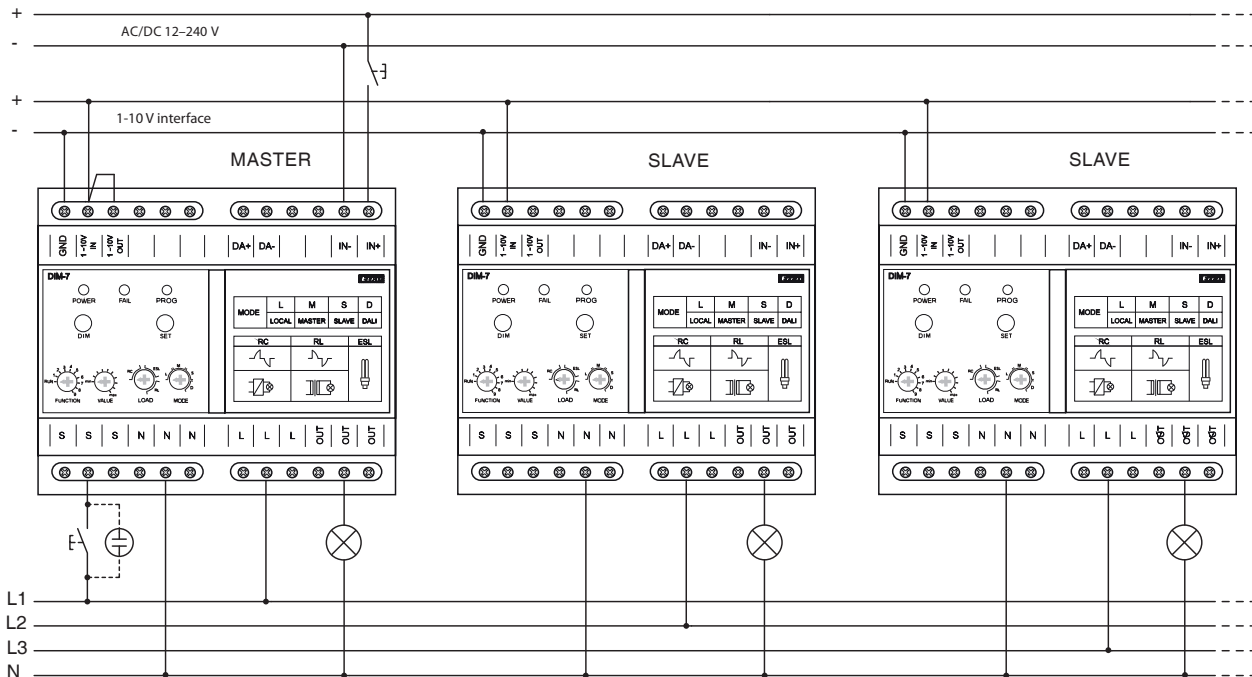

SLAVE

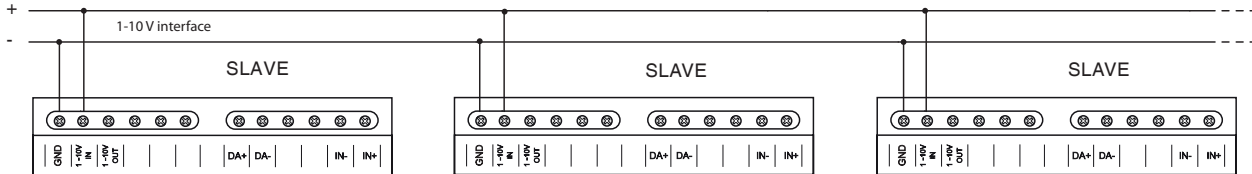

DALI

