

ELKO EP, s.r.o.
 Palackého 493
 769 01 Holešov, Všetuly
 Czech Republic
 Tel.: +420 573 514 211
 e-mail: elko@elkoep.com
 www.elkoep.com

Made in Czech Republic

02-28/2026



CRM-2T

STAR (λ)/ DELTA (Δ) time relay



Characteristic

- Designed for delayed start of 3-phase asynchronous motors to limit starting current and mechanical shock during start-up.
- Time t1 (star):
 - time range setting by rotary switch
 - fine time setting by potentiometer
- CRM-2T/UNI, CRM-2T/230V:**
 - time scale 0.1 s - 100 d divided into ten time ranges: 0.1 - 1 s / 1 - 10 s / 0.1 - 1 m / 1 - 10 m / 0.1 - 1 h / 1 - 10 h / 0.1 - 1 d / 1 - 10 d / 3 - 30 d / 10 - 100 d
- CRM-2T/WUNI:**
 - time scale 0.1 s - 1 h divided into five time ranges: 0.1 - 1 s / 1 - 10 s / 0.1 - 1 m / 1 - 10 m / 0.1 - 1 h
- Time t2 (delay) between λ / Δ
 - fine time setting by potentiometer
- CRM-2T/UNI, CRM-2T/230V:**
 - time scale: 0.1 - 1 s
- CRM-2T/WUNI:**
 - time scale: 25 ms - 1 s
- Supply voltage: AC 230 V, AC/DC 12 - 240 V or AC/DC 24 - 480 V
- Output contact:
 - CRM-2T/230V, CRM-2T/UNI:** 2x changeover, 16 A
 - CRM-2T/WUNI:** 2x closing, 8 A
- Multifunction red LED flashes or shines depending on the operating state.

Connection

CRM-2T/UNI
 CRM-2T/230V

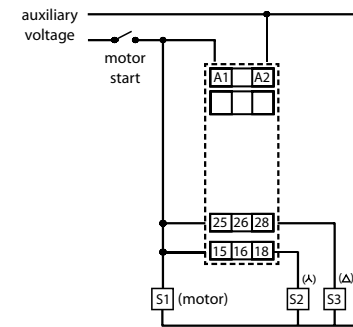

CRM-2T/WUNI

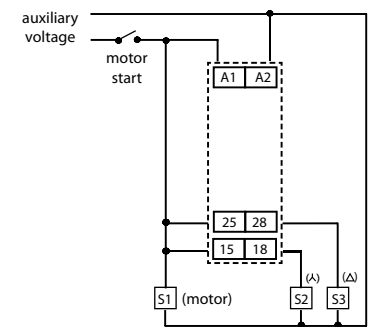

CRM-2T/UNI
 CRM-2T/230V
 CRM-2T/WUNI

Motor start-up (λ-Δ)

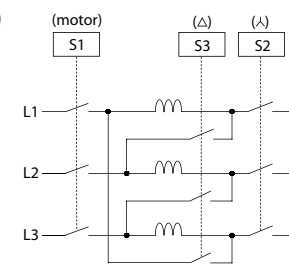

Description

CRM-2T/UNI
 CRM-2T/230V

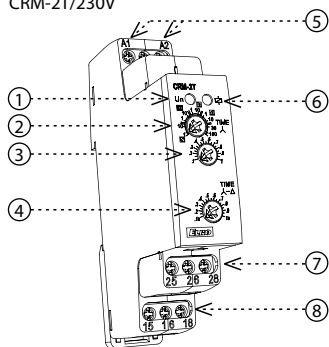

- Supply voltage indication
- Time range setting t1
- Fine time setting t1
- Fine time setting t2
- Supply voltage terminals (A1-A2)
- Indication of operating states
- Output contact 2 (25-26-28)
- Output contact 1 (15-16-18)

CRM-2T/WUNI

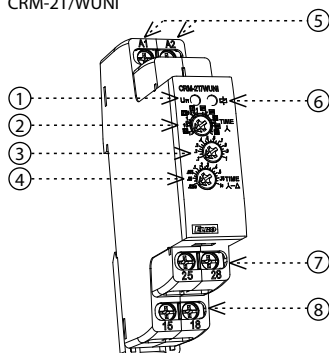

- Supply voltage indication
- Time range setting t1
- Time range setting t1
- Fine time setting t2
- Supply voltage terminals (A1-A2)
- Indication of operating states
- Output contact 2 (25-28)
- Output contact 1 (15-18)

Symbol

CRM-2T/230V
 CRM-2T/UNI

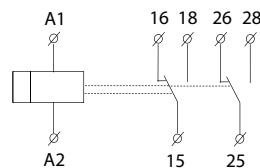

CRM-2T/WUNI

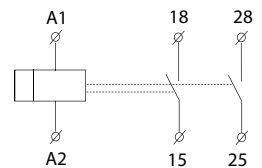

Function

STAR/DELTA

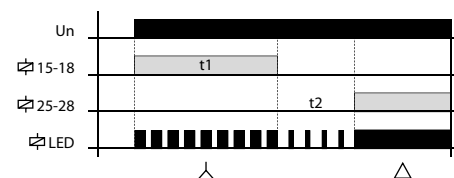

Tip for more accurate setting of timing (long periods of time)

Example of setting an 8 h delay:

On the potentiometer for setting the time range, set the range to 10 s.

Set the fine time setting potentiometer to 8 s (position .8), check the accuracy of the setting (e.g. with a stopwatch). This will verify the accuracy and minimum deviation of the potentiometer for fine time setting.

Then move the time range potentiometer to 10 h and leave the fine time setting unchanged. This will give you a seemingly accurate time of 8 h without the need for real-time verification.

CRM-2T/UNI; 230V CRM-2T/WUNI

Power supply

Supply terminals:	A1-A2	
Supply voltage:	UNI	AC/DC 12 – 240 V (AC 50-60 Hz)
Consumption (max.):		2 VA/1.5 W
Supply voltage:	230V	AC 230 V (50-60 Hz)
Consumption (max.):		3 VA/1.4 W
Supply voltage:	WUNI	AC/DC 24 – 480 V (AC 50-60 Hz)
Consumption (max.):		1.5 VA/1 W
Supply voltage tolerance:	-15 %; +10 %	

Time circuit

Time ranges:	t1: 0.1 s – 100 d, t2: 0.1 – 1 s	t1: 0.1 s - 1 h, t2: 25 ms - 1 s
Time setting:	rotary switch and potentiometers	
Time deviation:	5 % – mechanical setting	
Repeat accuracy:	0.2 % – set value stability	
Temperature coefficient:	0.01 %/°C, at = 20 °C (0.01 %/°F, at = 68 °F)	
Recovery time (max.):	150 ms	200 ms

Output



















Contact type:	2x changeover/SPDT (AgNi)	2x closing/SPST (AgNi)
Current rating:	16 A/AC1; PD. B300	8 A/AC1; PD. B300
Breaking capacity:	4000 VA/AC1, 384 W/DC1	2000 VA/AC1, 192 W/DC1
Inrush current:	30 A/< 3 s	10 A/< 3 s
Switching voltage:	AC 250 V/DC 24 V	
Power dissipation (max.):	2.4 W	1.2 W
Mechanical life:	10.000.000 ops.	60.000.000 ops.
Electrical life (AC1):	100.000 ops.	150.000 ops.

Other information



















Operating temperature:	-20 .. +55 °C (-4 .. +131 °F)	
Storage temperature:	-30 .. +70 °C (-22 .. +158 °F)	
Dielectric strength:		
supply - output 1	AC 4 kV	
supply - output 2	AC 4 kV	
output 1 - output 2	AC 4 kV	
Operating position:	any	
Mounting:	DIN rail EN 60715	
Protection degree:	IP40 front panel/IP20 terminals	
Overvoltage category:	III.	
Pollution degree:	2	
Cross-wire section; solid/ stranded with ferrule (max.):	1x 4 (12), 2x 1.5 mm ² (16 AWG)/ 1x 2.5 (14), 2x 1 mm ² (17 AWG)	1x 4 (12), 2x 2.5 mm ² (14 AWG)/ 1x 4 (12), 2x 1.5 mm ² (16 AWG)
Dimensions:	90 x 17.6 x 64 mm	
Weight:	UNI - 78 g (2.8 oz), 230 - 73 g (2.6 oz), WUNI - 71 g (2.5 oz)	
Standards:	EN 61812-1	

Device is designed for connection in 1-phase network AC 230 V, AC/DC 12 - 240 V or AC/DC 24 - 480V and must be installed in accordance with the regulations and standards applicable in the state of application. Installation, connection, setting and maintenance may only be carried out by a person with appropriate electrical qualifications who is fully familiar with the instructions and the function of the device. This device contains protection against overvoltage peaks and disturbances in supply. For correct function of the protection of this device there must be suitable protections of higher degree (A, B, C) installed in front of them. According to standards elimination of disturbances must be ensured. Before installation the main switch must be in position "OFF" and the device should be de-energized. Don't install the device to sources of excessive electro-magnetic interference. By correct installation ensure ideal air circulation so in case of permanent operation and higher ambient temperature the maximal operating temperature of the device is not exceeded. For installation and setting use screw-driver cca 2 mm. The device is fully-electronic - installation should be carried out according to this fact. Non-problematic function depends also on the way of transportation, storing and handling. In case of any signs of destruction, deformation, non-function or missing part, don't install and claim at your seller it is possible to dismount the device after its lifetime, recycle, or store in protective dump.

CRM-2T/UNI, CRM-2T/230V

Type of load	 cos φ ≥ 0.95 AC1	 AC2	 AC3	 AC5a uncompensated	 AC5a compensated	 AC5b	 AC6a	 AC7b	 AC12
Contact material AgNi, 16 A	250V / 16A	250V / 5A	250V / 3A	230V / 3A (690VA)	x	800W	x	250V / 3A	250V / 10A
Type of load	 AC13	 AC14	 AC15	 DC1	 DC3	 DC5	 DC12	 DC13	 DC14
Contact material AgNi, 16 A	250V / 6A	250V / 6A	250V / 6A	24V / 16A	24V / 6A	24V / 4A	24V / 16A	24V / 2A	24V / 2A

CRM-2T/WUNI

Type of load	 cos φ ≥ 0.95 AC1	 AC2	 AC3	 AC5a uncompensated	 AC5a compensated	 AC5b	 AC6a	 AC7b	 AC12
Contact material AgNi, 8 A	250V / 8A	250V / 3A	250V / 2A	230V / 3A (690VA)	x	300W	x	250V / 1A	250V / 1A
Type of load	 AC13	 AC14	 AC15	 DC1	 DC3	 DC5	 DC12	 DC13	 DC14
Contact material AgNi, 8 A	x	250V / 3A	250V / 3A	24V / 8A	24V / 3A	24V / 2A	24V / 8A	24V / 2A	x